

REV.	DESCRIPTION	DATE	BY

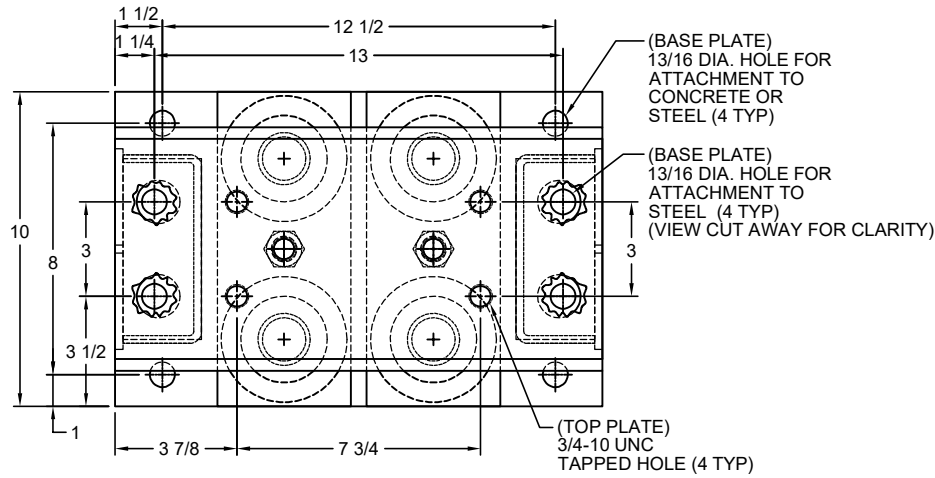

MODEL M4SH-2E SEISMICALLY RESTRAINED VIBRATION ISOLATOR FOR 2" DEFLECTION

SEISMIC MOUNT	RATED LOAD (LBS)	RATED DEFLECTION (IN)	SPRING RATE (LBS/IN)	COLOR CODE
M4SH-2E-4000	4000	2.00	2000	TAN
M4SH-2E-5600	5600	1.87	3000	RED
M4SH-2E-6400N ¹	6400	2.13	3000	TAN/ RED
M4SH-2E-7200	7200	1.71	4210	DK GRAY
M4SH-2E-8200	8200	1.64	5000	DK BLUE
M4SH-2E-9000N ¹	9000	1.62	5556	DK BLUE/BLACK
M4SH-2E-9840N ¹	9840	1.64	6000	DK BLUE/RED
M4SH-2E-10800N ¹	10800	1.64	6600	DK BLUE/DK GREEN

NOTE:
1. LOAD DETERMINED UTILIZING NESTED SPRINGS. THE COLOR CODE INDICATED IS FOR OUTER SPRING/INNER SPRING.

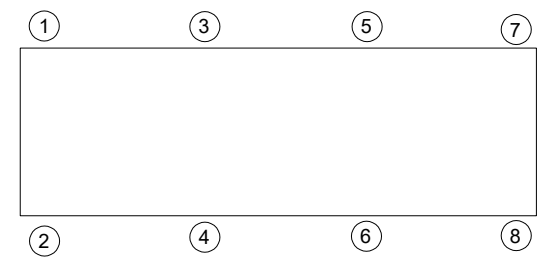
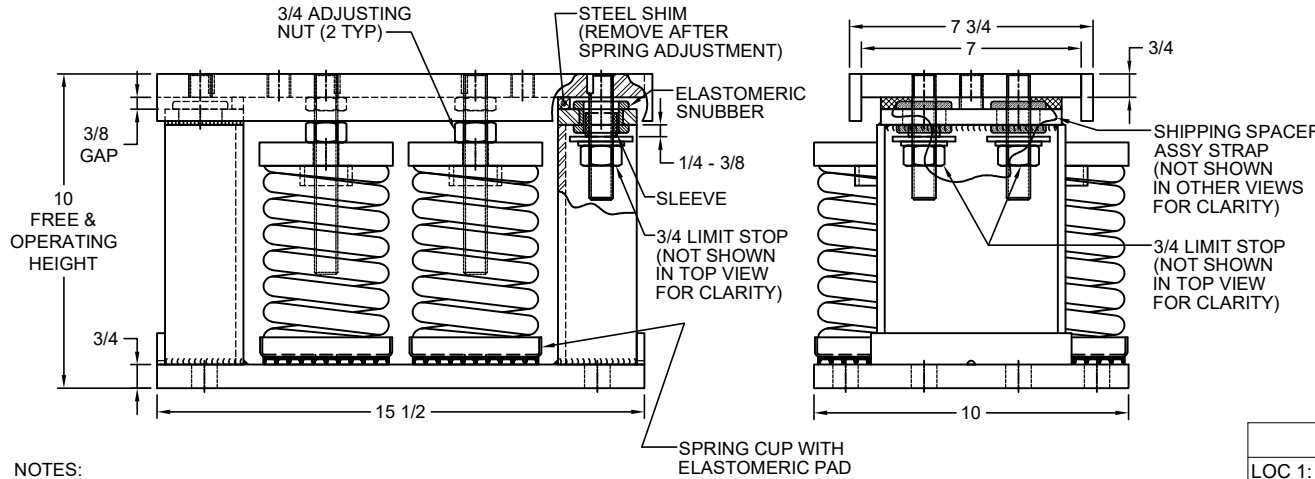

- NOTES:
- ALL DIMENSIONS ARE IN INCHES, INTERPRET PER ANSI Y14.
 - STANDARD FINISH: HOUSING - 1 COAT VMC STANDARD FINISH (COLOR:BLACK), SPRING - POWDER COAT (COLOR: SEE TABLE), HARDWARE ZINC-ELECTROPLATE.
 - EQUIPMENT MUST BE BOLTED OR WELDED TO THE TOP PLATE TO MEET ALLOWABLE SEISMIC RATINGS.
 - ISOLATOR BASE PLATE MUST BE ANCHORED TO CONCRETE WITH (4) 3/4" DIA. ANCHORS.
 - ALL SPRINGS ARE DESIGNED FOR 50% OVERLOAD CAPACITY.
 - REFER TO SHEET 2 OF 2 FOR INSTALLATION INSTRUCTIONS.
 - RATED DEFLECTIONS ARE WITHIN 25% OF NOMINAL. HIGHER DEFLECTIONS ARE ALLOWED IF THEY MEET SPECIFICATIONS.
 - ESTIMATED ISOLATOR SHIPPING WEIGHT: 121 LBS. ±8 LBS. TO ACCOUNT FOR SPRING VARIATIONS.

ISOLATOR SELECTIONS	
LOC 1:	LOC 2:
LOC 3:	LOC 4:
LOC 5:	LOC 6:
LOC 7:	LOC 8:
CUSTOMER EQP'T. TAG:	

NOTE: MATERIAL SHOWN IS FOR (1) SET.

OTHER MATERIALS, COMPOUNDS, OR FINISHES WITH EQUAL OR SUPERIOR PROPERTIES MAY BE SUBSTITUTED AS THEY BECOME AVAILABLE.

CERTIFIED FOR:

JOB NAME: _____

CUSTOMER: _____

CUSTOMER P.O.: _____

SALES ORDER: _____

MODEL M4SH-2E 4000-10800 LBS. VIBRATION ISOLATOR WITH INTEGRAL SEISMIC RESTRAINT AND INTERNAL ADJUSTMENT 2 INCH DEFLECTION



SCALE: NONE

SHEET: 1 OF 2

DRAWING NO.: _____ REVISION: _____



REV.	DESCRIPTION	DATE	BY

1. READ INSTRUCTIONS IN THEIR ENTIRETY BEFORE BEGINNING INSTALLATION.

2. ISOLATORS ARE SHIPPED FULLY ASSEMBLED AND ARE TO BE POSITIONED IN ACCORDANCE WITH THE SUBMITTAL DRAWINGS OR AS OTHERWISE RECOMMENDED.

3. SET ISOLATORS ON FLOOR, HOUSEKEEPING PAD, OR SUB-BASE, ENSURING THAT ALL ISOLATOR CENTERLINES MATCH THE EQUIPMENT MOUNTING HOLES. THE VMC GROUP RECOMMENDS THAT THE ISOLATOR BASE PLATES ("B") BE INSTALLED ON A LEVEL SURFACE. SHIM OR GROUT AS REQUIRED, LEVELING ALL ISOLATOR BASE PLATES AT THE SAME ELEVATION (1/4-INCH MAXIMUM DIFFERENCE CAN BE TOLERATED).

4. MARK ANCHOR HOLE LOCATIONS AS INDICATED ON BASE PLATE FOOTPRINT AND SET ISOLATOR ASIDE PRIOR TO DRILLING.

5. ANCHOR ALL ISOLATORS TO THE FLOOR, HOUSEKEEPING PAD, OR SUB-BASE USING MARKED HOLE LOCATIONS ("C") FOR CONCRETE OR ("D") FOR STEEL AS REQUIRED. USE ANCHORS MEETING THE DESIGN REQUIREMENTS SPECIFIED ON SHEET 1 OF 2. WELDING TO STEEL IS PERMITTED PROVIDING THE WELD ACHIEVES THE STRENGTH THAT IS REQUIRED TO SECURE MOUNT PER APPLIED LOADS.

6. ISOLATORS ARE SHIPPED TO THE JOBSITE WITH REMOVABLE SPACERS ("E") BETWEEN THE TOP PLATE AND THE BOTTOM HOUSING. THESE SPACERS MUST BE IN PLACE WHEN THE EQUIPMENT IS POSITIONED ON TOP OF THE ISOLATORS.

7. PLACE THE MACHINE OR EQUIPMENT ONTO TOP PLATE ("A") OF THE ISOLATORS. BOLT EQUIPMENT SECURELY TO THE ISOLATORS USING MINIMUM (2) ASTM A325 OR SAE GR. 5 HIGH-STRENGTH BOLTS (BY OTHERS). WELDING IS PERMITTED PROVIDING THE WELD ACHIEVES THE REQUIRED STRENGTH.

8. THE ADJUSTMENT PROCESS CAN ONLY BEGIN AFTER THE EQUIPMENT OR MACHINE IS AT ITS FULL OPERATING WEIGHT.

9. BACK OFF EACH OF THE LIMIT STOP LOCKNUTS ("F") 1/4- TO 3/8-INCH FROM THEIR AS-SHIPED POSITION.

10. ADJUST EACH ISOLATOR IN SEQUENCE BY TURNING ADJUSTING NUT(S) ("G") ONE FULL CLOCKWISE TURN AT A TIME. REPEAT THIS PROCEDURE ON ALL ISOLATORS, ONE AT A TIME. CHECK THE LIMIT STOP LOCKNUTS ("F") PERIODICALLY TO ENSURE THAT CLEARANCE BETWEEN THE WASHER AND RUBBER GROMMET IS MAINTAINED. STOP ADJUSTMENT OF AN ISOLATOR ONLY WHEN THE TOP PLATE ("A") HAS RISEN JUST ABOVE THE SPACERS ("E").

11. REMOVE ALL SPACERS ("E").

12. FINE ADJUST ISOLATORS TO LEVEL EQUIPMENT.

13. ADJUST ALL LIMIT STOP LOCKNUTS ("F") BACK UP TO OBTAIN 3/8-INCH GAP AS SHOWN. THE LIMIT STOP LOCKNUTS MUST BE KEPT AT THIS 3/8-INCH GAP TO ENSURE UNIFORM BOLT LOADING DURING UPLIFT (AS IN THE CASE WHEN A COOLING TOWER IS DRAINED).

14. INSTALLATION IS COMPLETE.

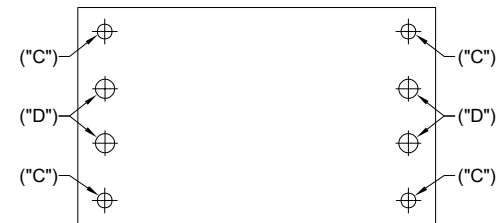
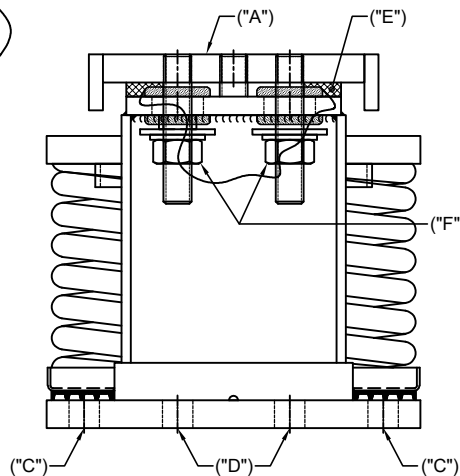
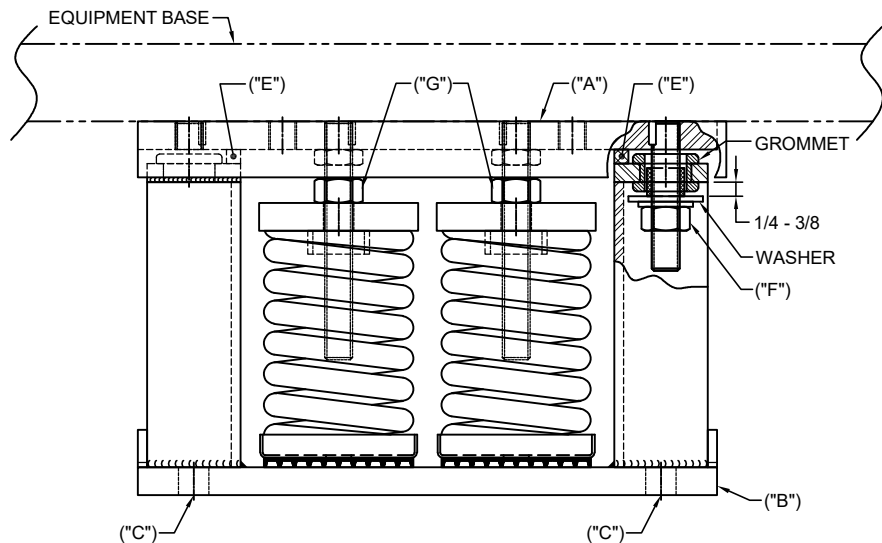

4. **BASE PLATE HOLE LOCATION DIAGRAM**
NOTE: ISOLATOR BASE PLATE IS TO BE USED FOR HOLE LOCATION MARKING ONLY AND NOT AS A DRILLING GUIDE.

OTHER MATERIALS, COMPOUNDS, OR FINISHES WITH EQUAL OR SUPERIOR PROPERTIES MAY BE SUBSTITUTED AS THEY BECOME AVAILABLE.



CERTIFIED FOR:

JOB NAME: _____
 CUSTOMER : _____
 CUSTOMER P.O.: _____
 SALES ORDER: _____

**MODEL M4SH-2E 4000-10800 LBS.
 VIBRATION ISOLATOR WITH
 INTEGRAL SEISMIC RESTRAINT
 AND INTERNAL ADJUSTMENT
 2 INCH DEFLECTION**



VMC GROUP
 THE POWER OF TOGETHER™
 Bloomingdale, NJ 07403
 Houston, TX 77041

SCALE:	NONE
SHEET:	2 OF 2



DRAWING NO.:	REVISION
--------------	----------